



SETTING UP A CARDIOID SUBWOOFER SYSTEM

Joan La Roda
DAS Audio, Engineering Department.

Introduction

In general, we say that a speaker, or a group of speakers, radiates with a cardioid pattern when it radiates more energy forward than it does backward. Strictly speaking, however, a cardioid pattern is heart shaped (hence the name) and is represented mathematically by the equation $\rho = (1 + \cos \sigma)$, where σ represents the horizontal angle.

Setting up subwoofers such that they radiate this way is a relatively simple task. One just needs to know what steps to follow as well as how to use one of several measurement systems that provide a transfer function mode.

There exist several cardioid subwoofer configurations, but the method to be followed, as described here, is always the same. This article does not intend to assess the various configurations, but only to show the basic procedures and ease the learning process. The user should choose the most appropriate configuration for the specific application needs.

Throughout this article we'll see measurements performed using SATLive. Phase curves are shown on the bottom part of the image, while the magnitude frequency response will be at the top of the image.

What applications is a cardioid subwoofer configuration appropriate for?

There are several situations where cardioid configurations can be useful. For instance, when using conventional subwoofers with a wall behind them, the back wave will bounce back and cancellations will happen at the front (let's not forget that subwoofers radiate in all directions). In other words, the reflected wave from the back wall will arrive at a different time with respect to the direct wave, i.e., there will be a phase difference between them that will create destructive interference. A cardioid configuration will radiate very little pressure backward, hence minimising that effect.

When using a L-R subwoofer configuration, especially on a small stage or at an indoor venue, we can help the monitor mixing engineer do his job by "cleaning" subwoofer frequencies, which can mask instruments, off the stage. With a cardioid configuration, clarity will be gained on stage.

A common subwoofer configuration is to group all the units together in front of the centre of the stage, forming a single line. Subwoofers may be fed a stereo signal or the output from a mixer's aux group. This arrangement has pros, but also a few cons: since subwoofers radiate in all directions, there will be a pressure maximum on the stage,

behind the subwoofers. This can end up being annoying for some musicians (not for all), as well as making the job of the stage mixing engineer more complicated, as we have mentioned before. A solution would be to make the subwoofers radiate as little as possible towards the back by using a cardioid configuration.

When speaking of cardioid configurations, users will often complain that they need to add cabinets to the system “just” to produce “less sound”. For instance, some configurations require twice the number of cabinets that would be normally used. While it is true that a full 6dB is not gained when duplicating the number of cabinets for a cardioid configuration, not all the energy is used to cancel the back wave. Some pressure will be gained at the front, as we’ll see in some of the examples.

In any case, we may not have enough subwoofer cabinets for a cardioid setup at a large, open air, concert, but we probably do for a gig at a small venue that uses a small amount of equipment. It should not be too much of a hassle to bring, say, six subwoofers instead of the four initially planned for. The musicians will be happy and our monitor engineers will be able to work more comfortably.

Some cardioid configurations

Figure 1 shows some cardioid configurations. Depending on the available space, stage height, our experience with each of the setups, etc. you may choose one over another.

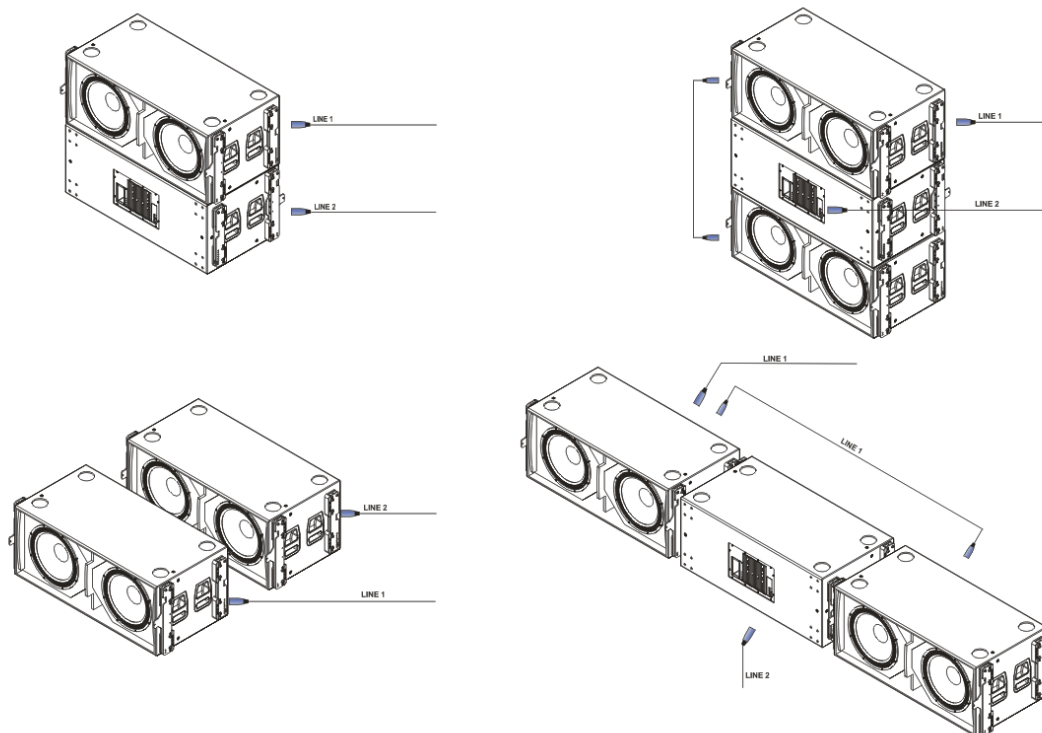

Fig. 1. Four different cardioid configurations.



Basic knowledge

For better understanding of the rest of the article, let's go over the following concepts:

Speed of sound in air.

It is represented by the letter “c” and is temperature dependent. It is 344.2 m/s at 22°C (71.6°F). Incidentally, the speed of sound is the same at all frequencies.

Wavelength.

Represented by the greek letter “λ” (lambda). It can be calculated from equation

$\lambda = c / f$, where c is the speed of sound and f is frequency.

If the speed of sound is in metres per second [m/s] and frequency is in hertz [Hz], the result will be in metres.

Period.

Represented by the letter T, it is the time one cycle takes to complete at a given frequency. It is given by

$T = 1 / f$, where f is frequency.

If frequency is in hertz [Hz], as would most commonly be, the result will be in seconds [s]. For milliseconds [ms], the result needs to be multiplied by 1000.

Octave.

There is an octave interval between two frequencies when one of them is twice the value of the other. For instance, between a frequency of 100Hz and 200Hz there is an interval of one octave, just like between 1500Hz and 3000Hz.



Example 1. “Scaled down measurements: one cabinet in front and one cabinet behind”

Before trying to do these adjustments for the first time in a real-life situation, where one may not always have enough time and where conditions are far from ideal, scaled down measurements can be handy to get some practice with the procedure.

We'll assume that you already know how to take transfer function measurements with the measurement system you are using, and that the equipment used is adequate.

As is the case with transfer function analysis, the reference signal needs to be synchronised to the measured subwoofer signal before a meaningful frequency response can be obtained. The coherence curve will normally be good enough unless there are strong reflections, excessive reverberation, widely differing levels for reference and measurement channels, hardware or software issues or if we forgot to synchronise the reference to the measurement signal.

Let's now run some scaled down measurements of 18" subwoofers.

Subwoofer cut-off frequencies are:

HPF LR24dB/Oct, 30Hz

LPF LR24dB/Oct, 85Hz

We'll use two 4" speakers to get some practice with the phase adjustment procedure. For our 4" to behave acoustically like our real, full scale systems, we will need to scale the crossover frequencies up.

To do that we'll multiply the real system cut-off frequencies by the ratio of the real system to our scaled down box, i.e., we will multiply the cut-off frequencies by $18"/4" = 4.5$

Therefore the cut-off frequencies for the scaled down measurements, which will be entered in the processor for the 4" system, will be as follows:

Cut-off frequencies for the scaled down subwoofer system are:

HPF LR24dB/Oct, $30\text{Hz} \times 4.5 = 135\text{Hz}$

LPF LR24dB/Oct, $85\text{Hz} \times 4.5 = 382\text{Hz}$

In this example we'll use two subwoofers, one in front of the other.



Cabinet spacing

Cabinet spacing is not random, but depends on a frequency we'll refer to as "reference frequency" throughout this article. The distance between cabinets will be 1/4th the wavelength of the "reference frequency". To choose this reference frequency correctly we need to consider and understand what goes on with phase both in front as well as behind this cardioid configuration once everything has been adjusted.

Back:

As we'll see below, we'll end up with a phase difference of 180° between the front and the back cabinet throughout the full pass band. The difference in level between the cardioid and conventional configurations will be easily perceived by ear.

Front:

There are three distinct zones within the subwoofer frequency band:

a) At the frequency that we chose as our reference, the phase value of each of the two subwoofers is the same, since the traces cross each other. That is, they will be in phase.

b) One octave above the frequency that we chose as our reference there is cancellation. That is, above the reference frequency the difference in phase gradually increases and reaches 180° one octave above the reference frequency. There would be cancellation if that frequency were within the subwoofer passband.

c) Below the reference frequency there is also a difference in phase between the back and the front subwoofers. However, the difference in phase increases at a slower rate when frequency decreases compared to when frequency increases. This is due to the fact that the spacing between the two subwoofers, and the delay being introduced, are less significant for low frequencies (long periods and wavelengths) than they are for high frequencies (short periods and wavelengths).

Now that we know that the choice of reference frequency is of importance, we need to figure out how to go about picking the frequency that will have the least effect on the amplitude frequency response at the front of our system.

Since we know that there will be cancellation one octave above the reference frequency, it is clear that we need to choose a frequency whose upper octave lies beyond our subwoofers' passband. Our first option would be to choose the upper crossover frequency for the subs.

It has been noted above that the spacing between the two subwoofers needs to be 1/4th of the wavelength of the reference frequency. It might be the case that, when choosing the upper crossover frequency as the reference frequency, a fourth of its wavelength happens to be just a bit larger than the depth of the sub (which would mean that the back



cabinet radiates too close to the front one, adding extra acoustical loading to the back sub) or it could even be shorter (in which case it would be physically impossible to place the subwoofers). In any of those instances, we'll be forced to choose a lower reference frequency.

Set-up for scaled down measurements

For the scaled down measurement in this example DAS Arco 4 loudspeakers cabinets have been used to simulate the subwoofers. The spacing has been chosen to correspond to 1/4th of the wavelength of the subwoofer upper crossover frequency.

Again, subwoofer cut-off frequencies are:

HPF LR24dB/Oct, 30Hz x 4.5 = 135Hz

LPF LR24dB/Oct, 85Hz x 4.5 = 382Hz

And the wavelength for the upper crossover frequency is:

$$\lambda = c/f = 344/382 = 0,9\text{m}$$

$$1/4\text{th of the wavelength is } \lambda/4 = 0,9/4 = 0.22\text{m} = 22\text{cm}$$

Downloaded from Doctor ProAudio.com

Figure 2 shows cabinet placement for this example. Cabinet front baffles are spaced 22cm, and, in this case, the distance from the back cabinet to the measurement microphone was 90cm.

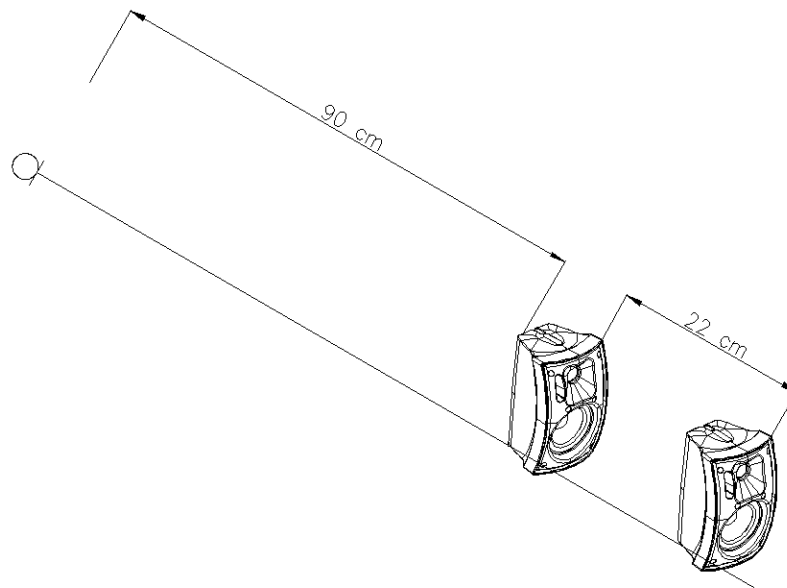

Fig. 2. Microphone placement and cabinet spacing for this example.

Once we have worked out what the cabinet spacing needs to be for this specific configuration, we can start with the procedure, which is shared by the rest of cardioid configurations shown in this article.

Procedure

The procedure is as follows:

- 1) Place the microphone behind the enclosures, at the spot where you want the cancellation to take place.
- 2) Start with just the front subwoofer band. We'll use the "Delay Finder" utility to add the required delay on SATLive to the channel carrying the reference signal. (See the user's manual for SATLive or your analysis software for more information).

3) Measure the magnitude frequency response for the front enclosure before doing phase adjustments. This way we'll be able to compare the initial situation with the cardioid configuration. The measurement can be seen in Figure 3. The subwoofer's phase trace will always be shaped like an upper case U letter, or a smile.

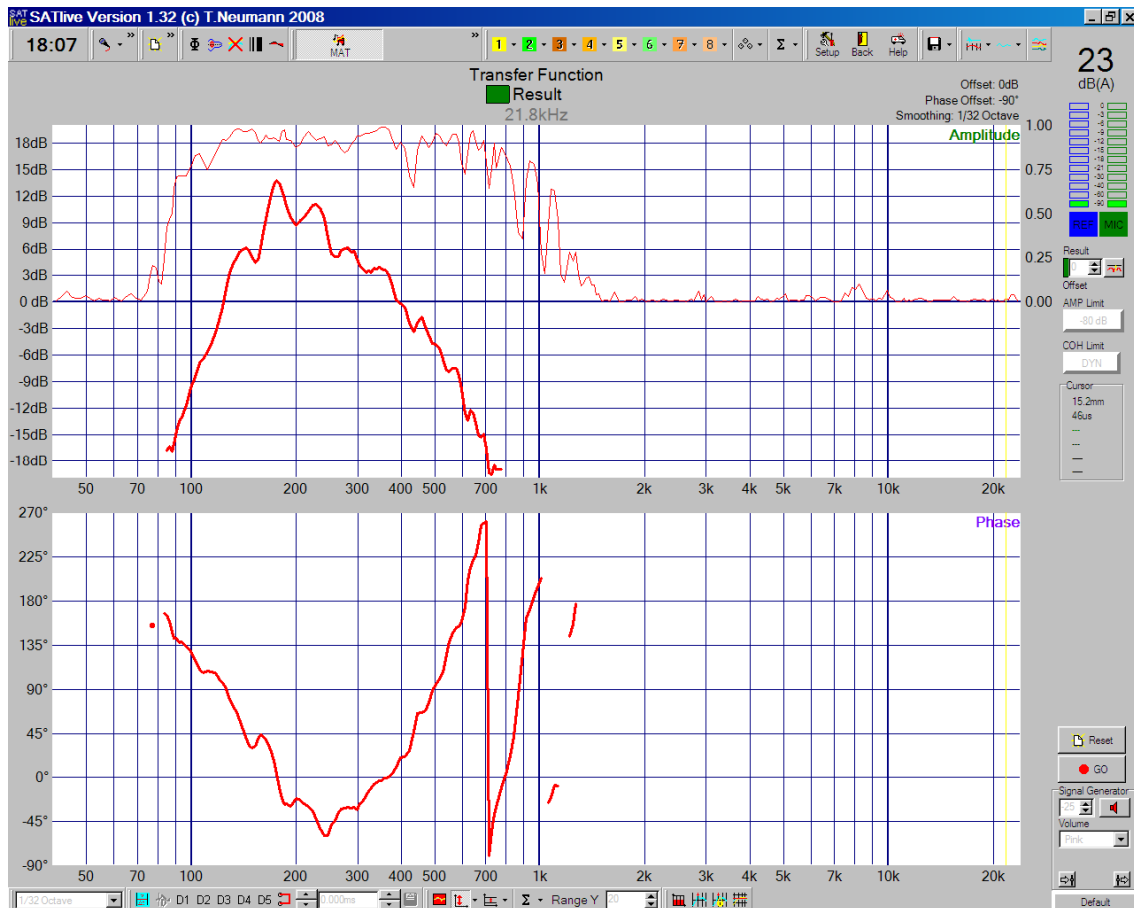

Fig. 3. Magnitude and phase frequency response for the front subwoofer at the position where the cancellation is required.

4) Mute the front subwoofer band and unmute the back subwoofer band.

5) Do not use the “Delay Finder” again!!! (i.e., do not synchronise the reference signal to the measured signal again). Remember that we are comparing phase on both subwoofers, i.e. we are measuring the difference in time arrival between the two signals as a function of frequency. Therefore the synchronisation delay for the reference signal should not be changed on the measurement software again.

6) Measure the back subwoofer band and compare the phase and amplitude curves with those of the front subwoofer. The result can be seen in Figure 4.

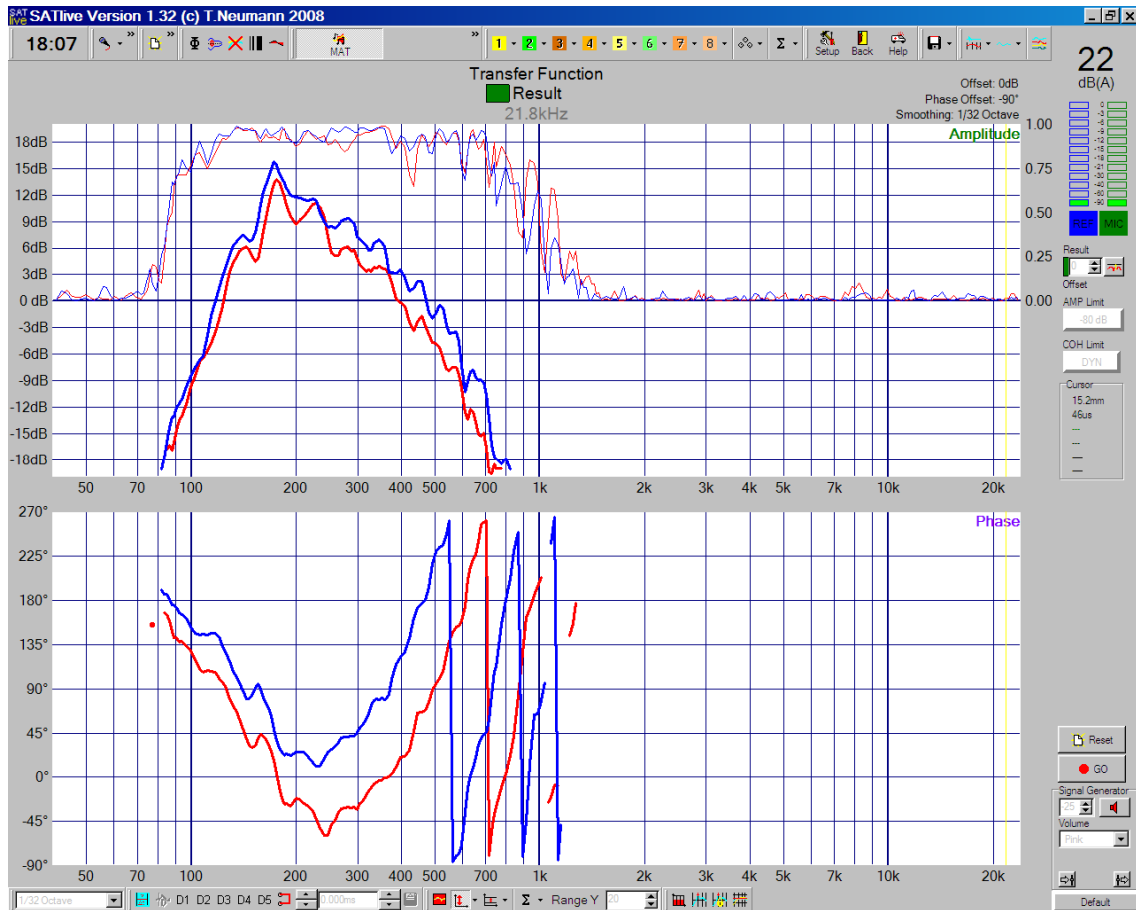

Fig. 4. Comparison of front (red) and back (blue) subwoofers. As expected, differences in phase and level can be noted.

7) If necessary, adjust the gain of the back subwoofer so as to match the level of the front subwoofer at the measurement position. If needed, you could always apply filtering (HPF, LPF or EQ) to match the levels in the whole of the subwoofer passband.

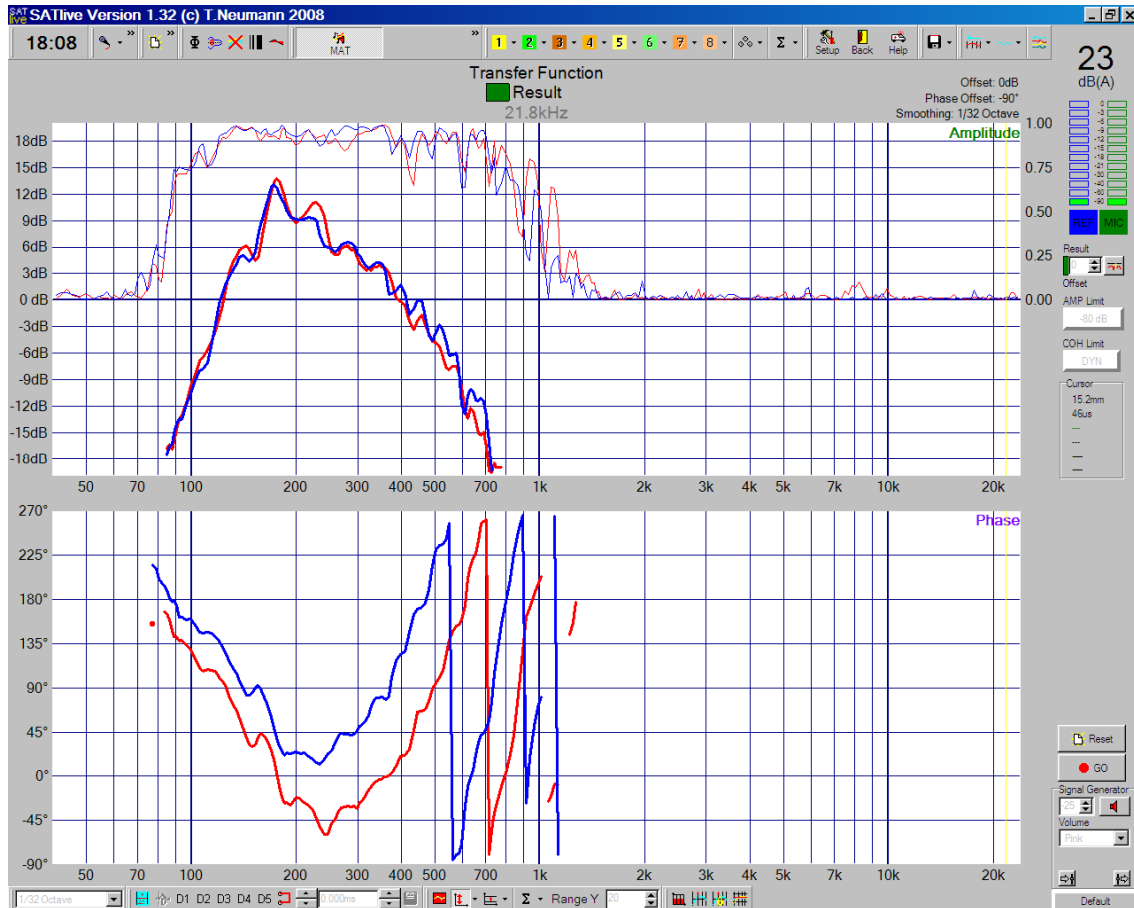

Fig. 5. For an optimum cancellation we need a phase difference of 180° between the two subwoofers as well as having equal amplitude. In this step the levels of the subwoofers have been matched by reducing the gain on the back enclosure (blue) by 2.5dB.

8) Add delay to the back subwoofer until its phase trace overlaps with that of the front subwoofer. Do not forget to save the curves.

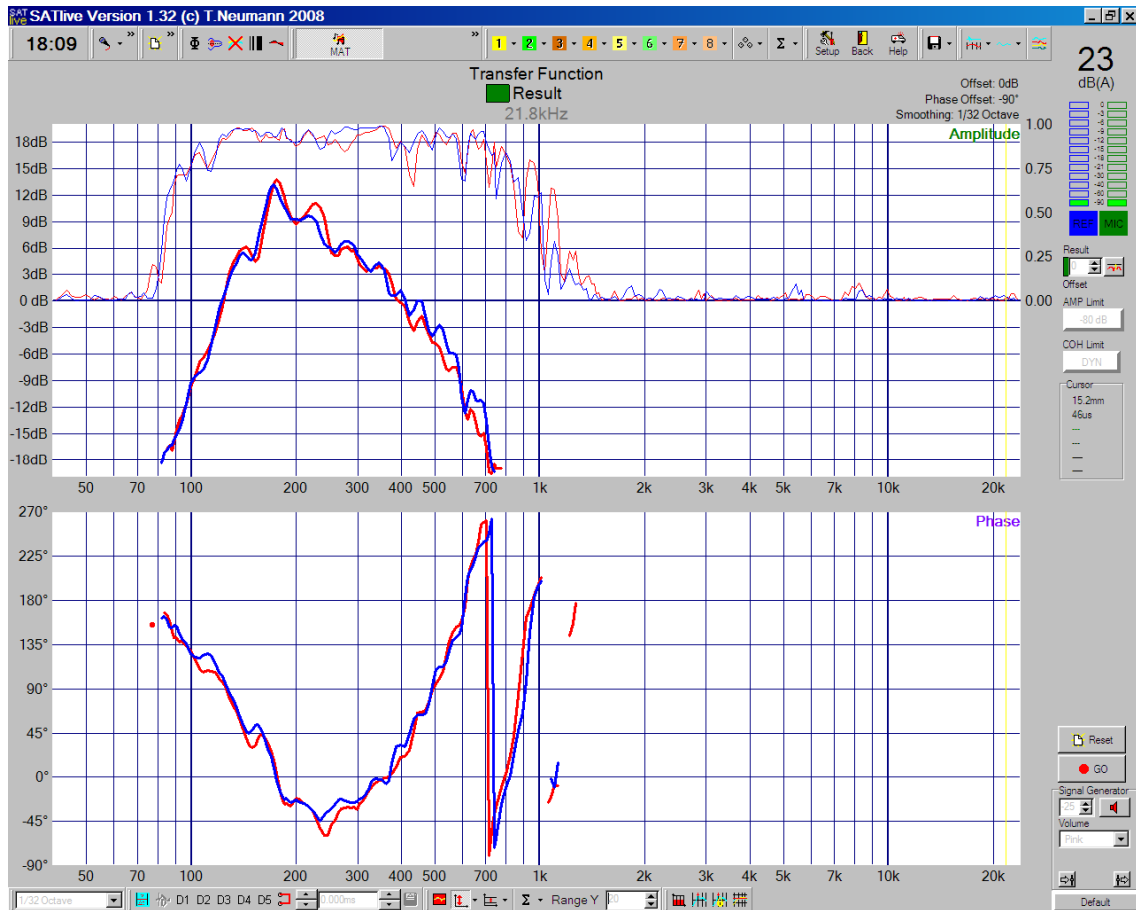

Fig. 6. When adding delay to the blue curve, its phase trace moves down until it overlaps with the red one. Delay added to the back subwoofer in this example was 0.658ms.

9) Invert polarity on the back subwoofer. The phase trace can be seen to shift 180°.

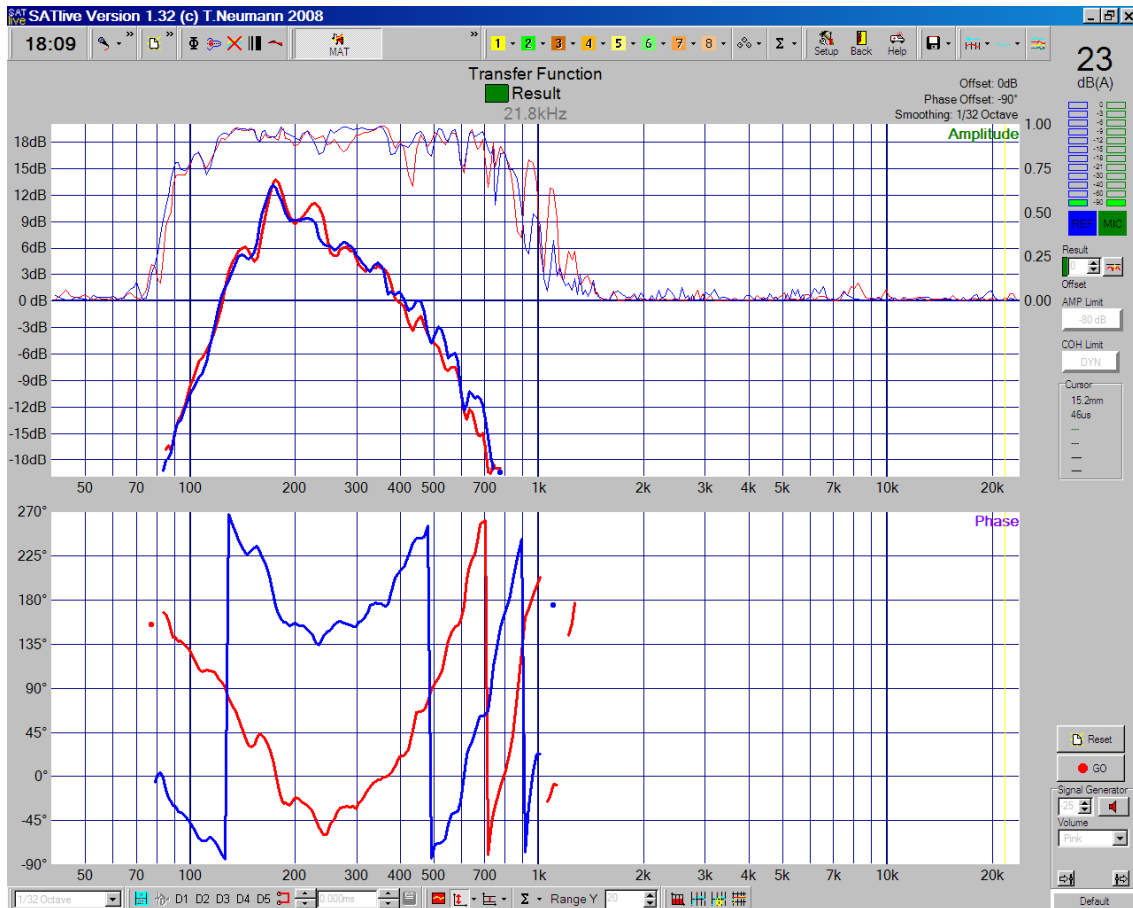

Fig. 7. When inverting polarity on the back subwoofer, the phase trace is the same as for the front one, but shifted 180°.

10) Unmute both the back and front subwoofers. Measure the amplitude response of the adjusted system and compare to the initial measurement for the front subwoofer. If the phases have been correctly adjusted we shall see a significant reduction in level.

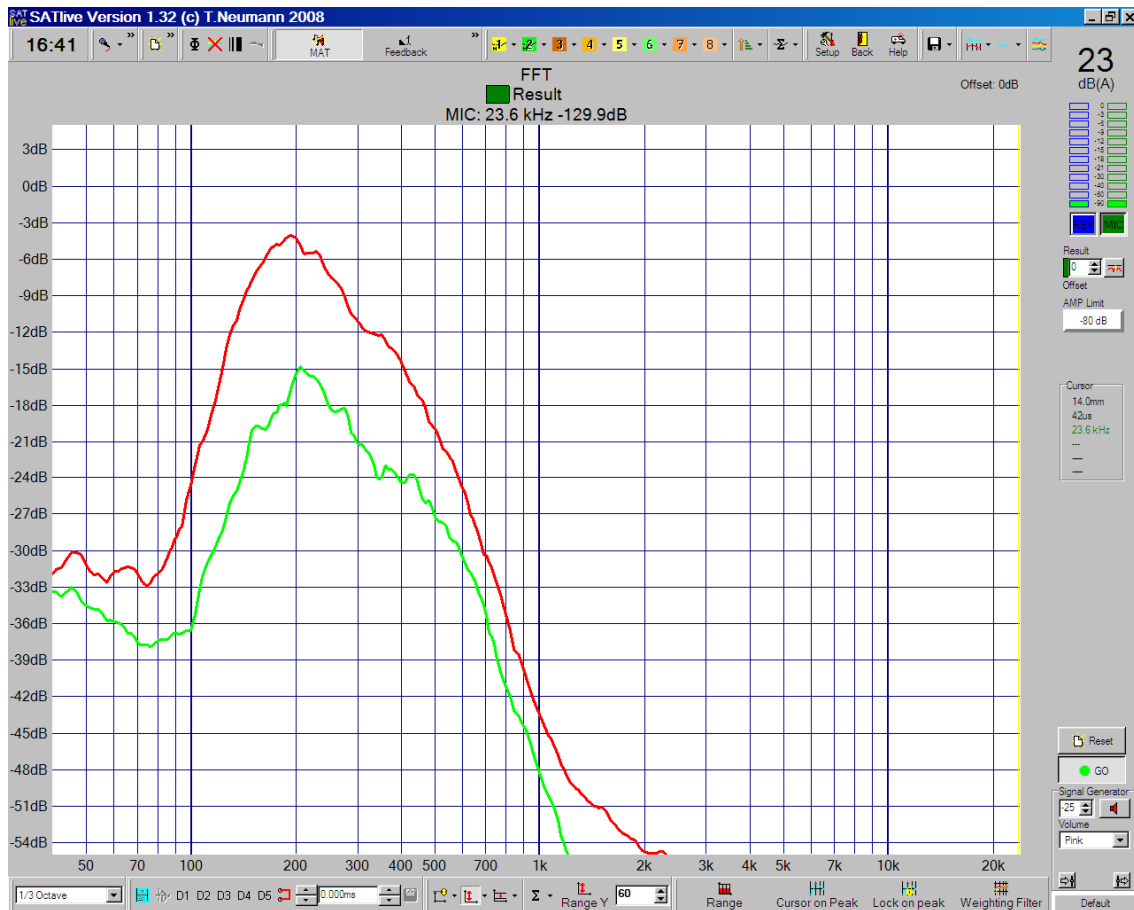

Fig. 8. This image compares the pressure curve of the front subwoofer at the measurement position (red) to the cardioid configuration (green). In this case, a difference of up to 12dB can be seen.

We recommend that you now listen to the result by walking from the front to the back, around the system. The difference should be remarkable.

You can also listen to the difference with pink noise by asking someone to mute the output of the back subwoofer.



11) Adjust the processor limiters so that both subwoofers limit at the same time.

In step 7 we reduced the gain on the back subwoofer output so that the output from both subwoofers were the same at the back of the arrangement (Keep in mind that, for optimum cancellation, phase difference needs to be 180° and levels need to be matched).

If we did not adjust the limiters this way, the front subwoofer would limit before the back one, so, for a moment, pressure levels would not be the same and there would be an annoying intermittent lack of cancellation.

This adjustment can be done with a music signal, varying the limiter threshold at the processor outputs so the limiting for the two signals takes place at the same time.

Downloaded from Doctor ProAudio.com

Sound pressure level in front of the cardioid configuration

Not all the back subwoofer energy is used for cancellation. At the front of the cardioid configuration, pressure is gained, compared to a conventional configuration (without a back subwoofer, that is).

Figure 9 shows the sound pressure difference between a single subwoofer and the cardioid configuration.

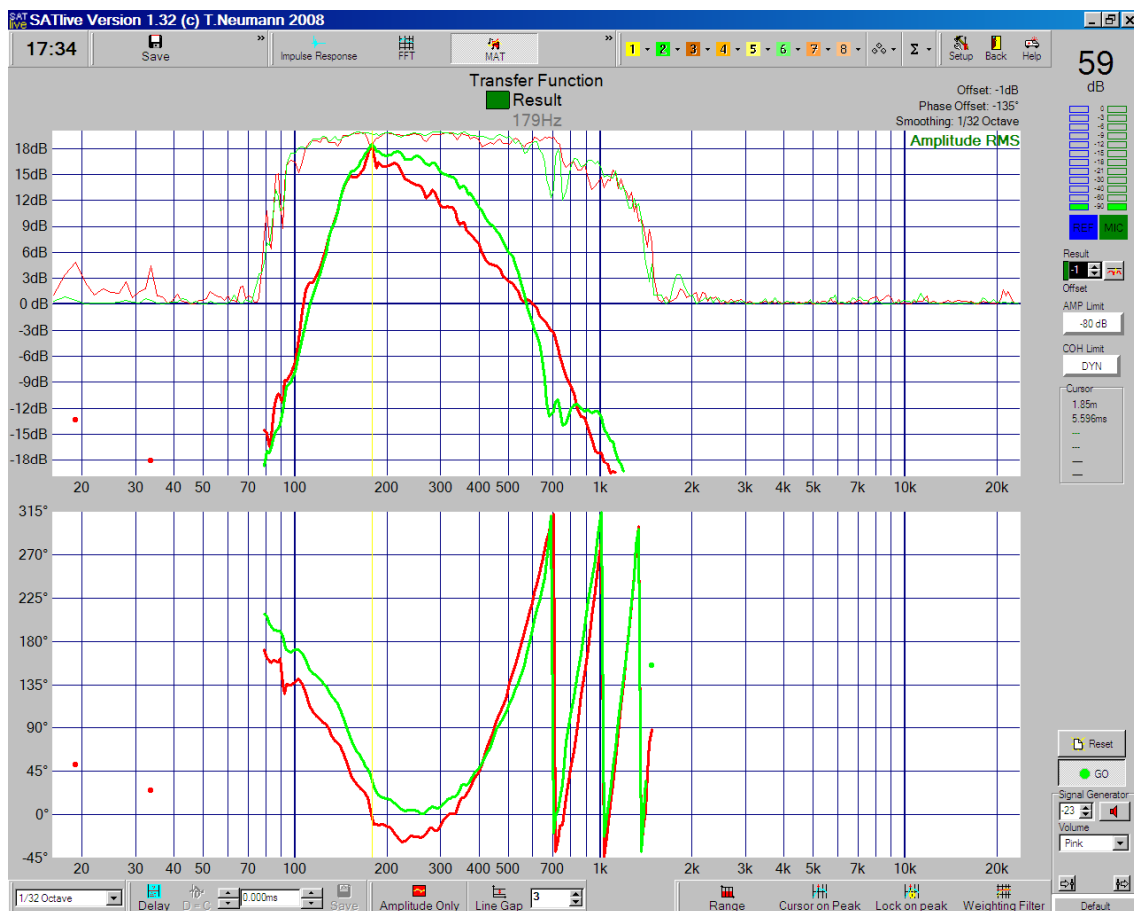

Fig. 9. Red traces correspond to the magnitude and phase responses for the front subwoofer alone, while the green ones are for the cardioid configuration. In this specific example, we have gained approximately 3dB between 170Hz and 500Hz, while levels below 170Hz have stayed the same.

As stated above, at twice what we call reference frequency there is a cancellation. On this example the reference frequency is 382Hz, which means that cancellation will happen at 764Hz. This is why there is an increase in the slope of the curve above 500Hz.

At the “Cabinet spacing” section we spoke of the phase differences at what we call reference frequency, as well as at frequencies above and below it. Figure 10 shows these phase differences. The red trace represents the front subwoofer while the blue trace corresponds to the back one.

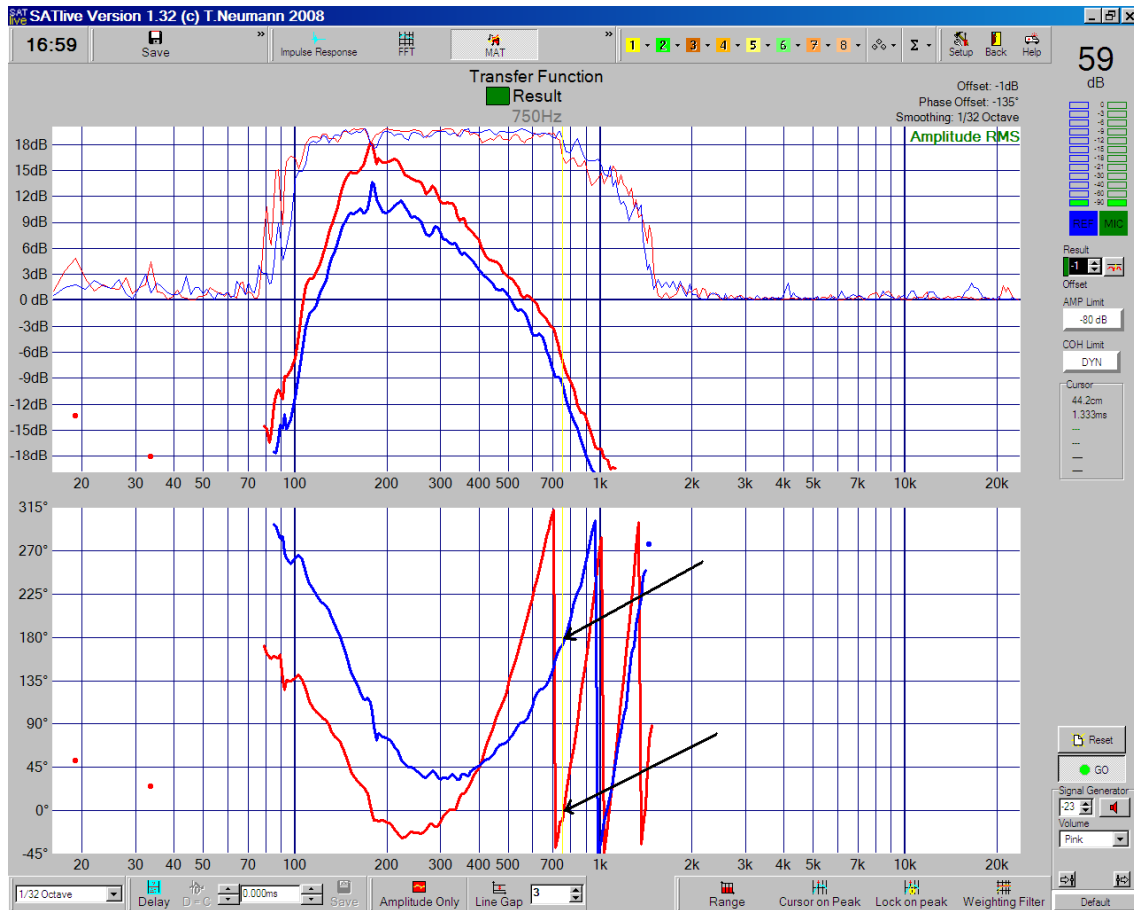

Fig. 10. Magnitude and phase responses for the front (red) and back (blue) subwoofers.

Above the reference frequency, where the curves cross each other, phase difference increases rapidly (taking into account that a logarithmic scale is used for frequency) until twice the reference frequency is reached and cancellation happens as a result of the 180° phase difference. In this example it can be seen that the blue phase curve is 0° at 764Hz while the red curve is 180° , i.e. a 180° phase difference. The black arrows mark both spots.

Below the reference frequency, phase difference is not as large as for the upper frequencies.

¿How does this configuration work?

As mentioned above, our goal is to achieve cancellation at the back. Therefore we first need to match the phase for the two subwoofers at the back and then we'll invert the polarity on the back subwoofer.

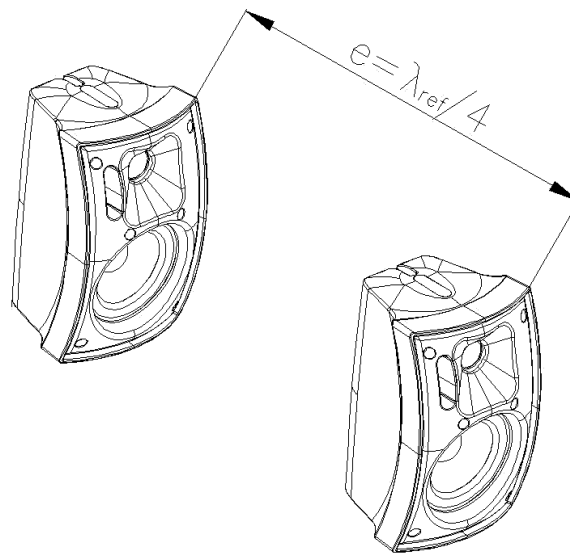

Fig. 11. Cabinet spacing is equal to a quarter wavelength of the reference frequency.

The wave coming out of the front subwoofer in Figure 11 reaches the front baffle of the back subwoofer with a delay that is a function of the distance between them. This distance is a quarter wavelength at the reference frequency, i.e. $\lambda_{ref} / 4$.

¿How long does it take for the wave of the front subwoofer to reach the back subwoofer?

We know that:

$$c = e / t, \text{ where}$$

c, is the speed of sound (344 m/s)

e, is distance

t, is time.

$$\text{From there, } t = e / c$$

Let's call t_{nb} the time it takes for the wave of the front subwoofer to reach the front baffle of the back subwoofer. We now solve for t to calculate t_{nb} ,

$$t_{nb} = e / c = (\lambda_{ref} / 4) / 344$$

If we now use a signal processor to add this delay time to the back subwoofer, both subwoofers will be in phase at the back. One could say that we are applying electronic delay to the back subwoofer so that it "waits" for the arrival of the wave of the front subwoofer, which gets there late due to the distance between both subwoofers. Inverting the polarity on the back subwoofer will produce cancellation.

Anechoic chamber measurements

Polar plots and isobar maps illustrate the effectiveness of this cardioid configuration.

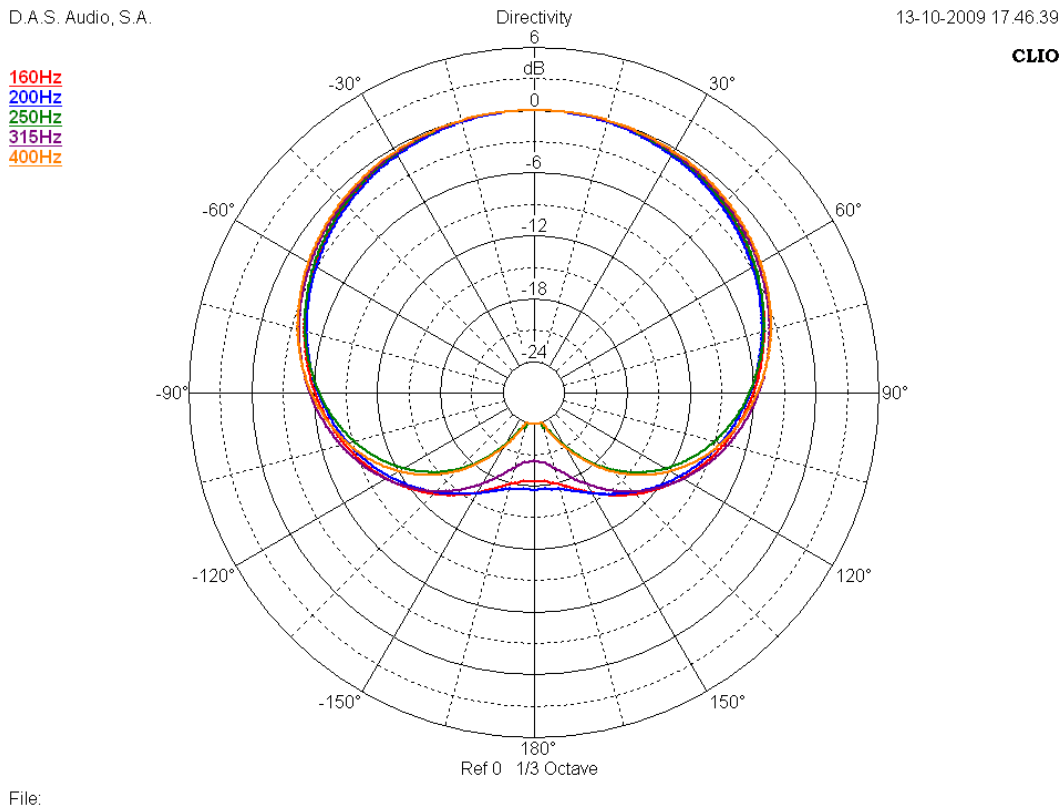

Fig. 12. Polar plots of the cardioid configuration as measured in the anechoic chamber.

It can clearly be seen that a cardioid, heart shaped, pattern is radiated, as desired. The pattern changes slightly with frequency. 160 Hz is the lowest frequency shown, as it corresponds to the anechoic chamber's frequency limit. Keep in mind that you should divide the frequencies shown by 4.5 to calculate the equivalent frequencies for an 18" subwoofer, so that 160 Hz in our scaled down exercise would correspond to 35.5 Hz.

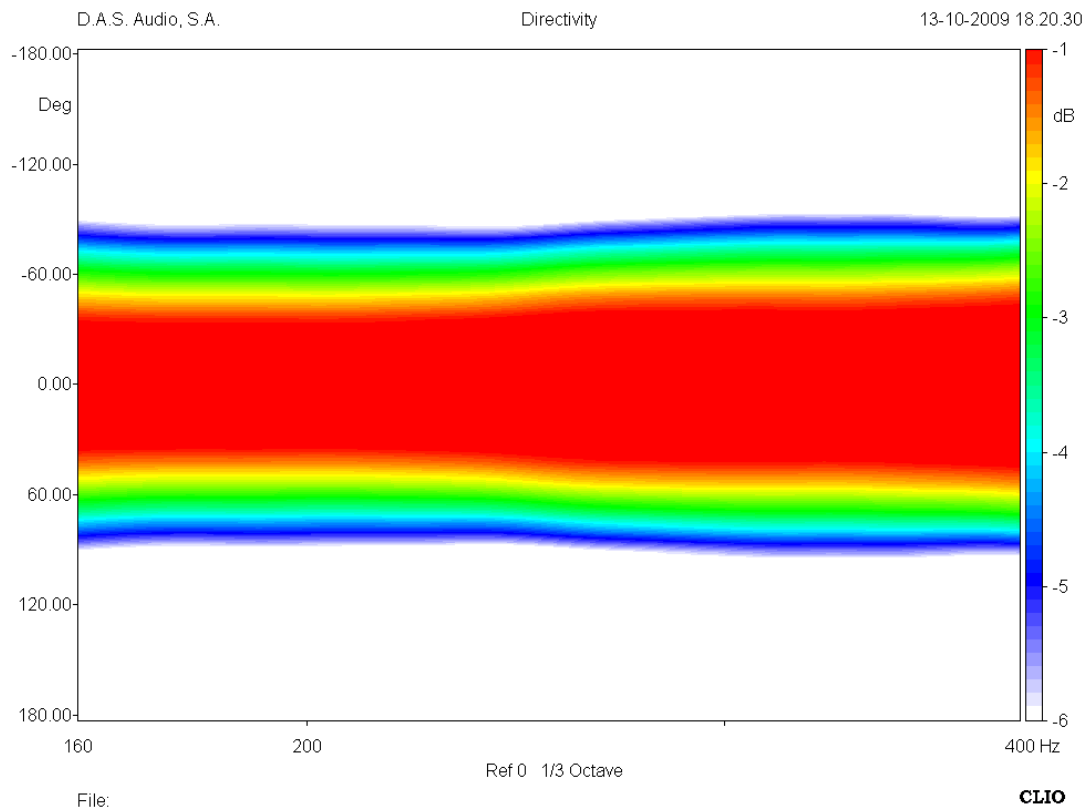

Fig. 13. Isobar map for the cardioid configuration.

Downloaded from Doctor ProAudio.com

Isobar maps represent a system's coverage in degrees (vertical axis) as a function of frequency (horizontal axis). The colour scale on the right-hand side shows that white colour (or the limit with blue) corresponds to -6dB with respect to the centre. It can be seen that we have roughly -6dB at +90° and -90° throughout the band, i.e. a coverage of 180°.

Example 2. “Scaled down measurements: three subwoofers on a straight line, two facing forward and one backward.”

In this case there is no need to define the spacing between cabinets since they all share a single straight line, which also means that this arrangement is easier than example 1. The procedure will be the same, without the hassle of having to choose the distance between cabinets and the reference frequency.

Figure 14 shows the positioning of the subwoofers and the microphone. The two cabinets on the sides, pointing forward, share the same signal.

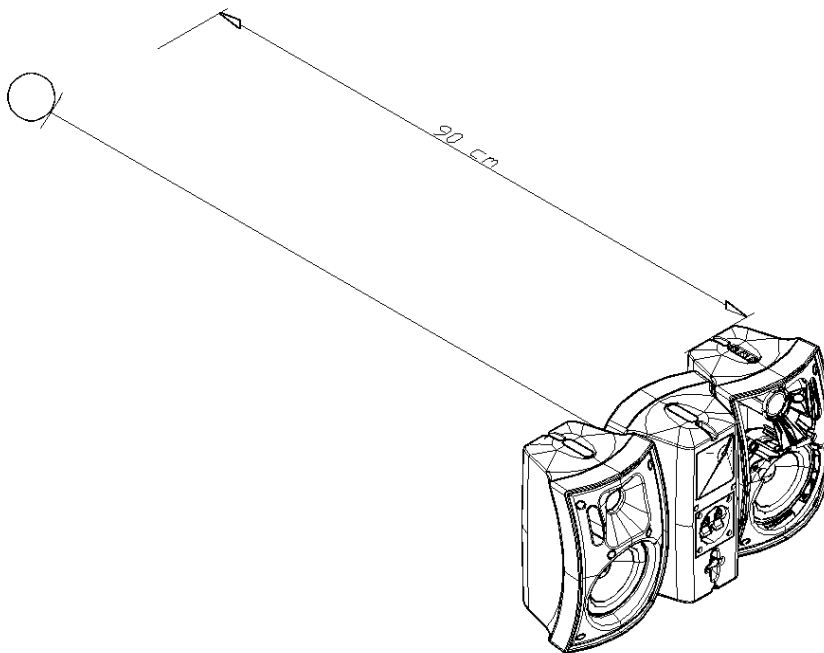

Fig. 14. Positioning of the microphone and cabinets for this example.

The procedure is as follows:

- 1) Place the microphone behind the enclosures, at the spot where we want the cancellation to take place.
- 2) Start with just the band that drives the forward facing subwoofers. We'll use the “Delay Finder” utility to add the required delay on SATLive to the channel carrying the reference signal. (See the user's manual for SATlive or your analysis software for more information).

3) Measure the magnitude frequency response for the enclosures facing forward before doing phase adjustments. This way we'll be able to compare the initial situation with the cardioid configuration. The measurement can be seen in Figure 15. The subwoofers' phase trace will always be shaped like an upper case U letter, or a smile.

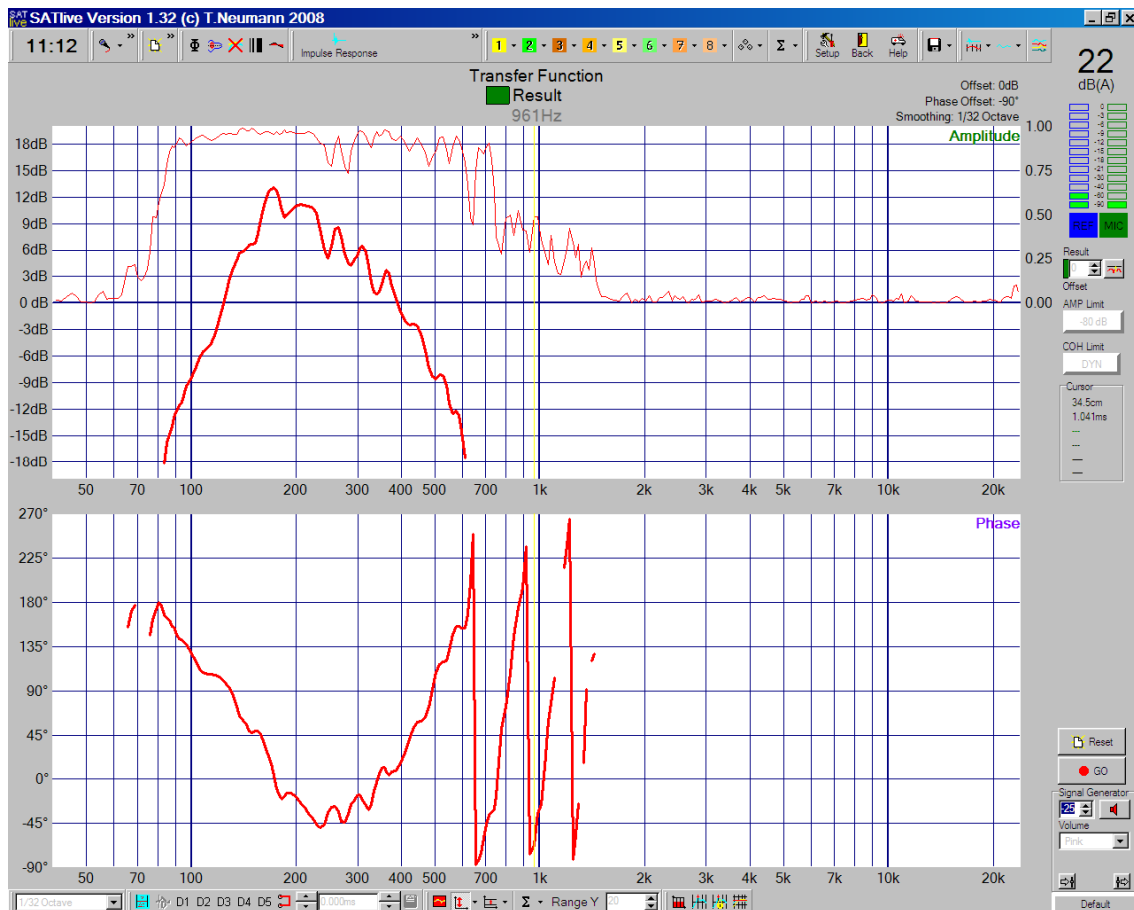

Fig. 15. Magnitude and phase curves for the subwoofers facing forward at the position where the cancellation is required.

4) Mute the forward facing subwoofers and unmute the backward facing subwoofer.

5) Do not use the “Delay Finder” again!!! (i.e., do not synchronise the reference signal to the measured signal again). Remember that we are comparing phase on the subwoofers, i.e. we are measuring the difference in time arrival between the two signals as a function of frequency. Therefore the synchronisation delay for the reference signal should not be changed on the measurement software again.

6) Measure the backward facing subwoofer and compare the phase and amplitude curves with those of the forward facing subwoofers. The result can be seen in Figure 16.



Fig. 16. Comparison of forward facing (red) and backward facing (blue) subwoofers. As expected, differences in phase and level can be noted.

7) If necessary, adjust the gain of the backward facing subwoofer so as to match the level of the forward facing subwoofers at the measurement position. If needed, you could always apply filtering (HPF, LPF or EQ) to match the levels in the whole of the subwoofer passband.

In this case we've had to increase the gain of the backward facing subwoofer by 4dB as well as applying low-pass filtering at 270Hz to match levels throughout the passband.

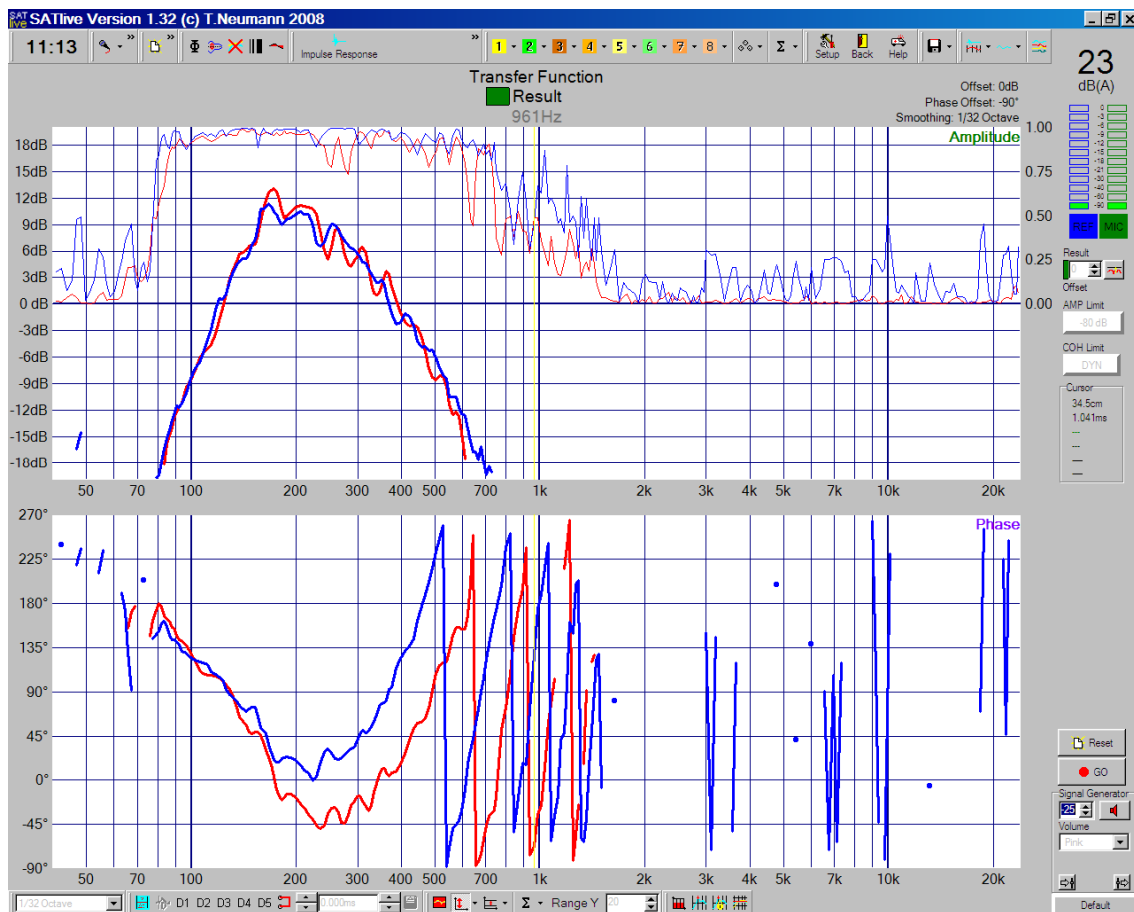

Fig. 17. For an optimum cancellation we need a phase difference of 180° between the two subwoofers as well as having equal amplitude. In this step the levels have been matched by increasing the gain of the backward facing subwoofer by 4dB as well as applying low-pass filtering at 270Hz (blue trace).

8) Add delay to the subwoofer facing backward until its phase trace overlaps with that of the subwoofers facing forwards. Do not forget to save the curves.

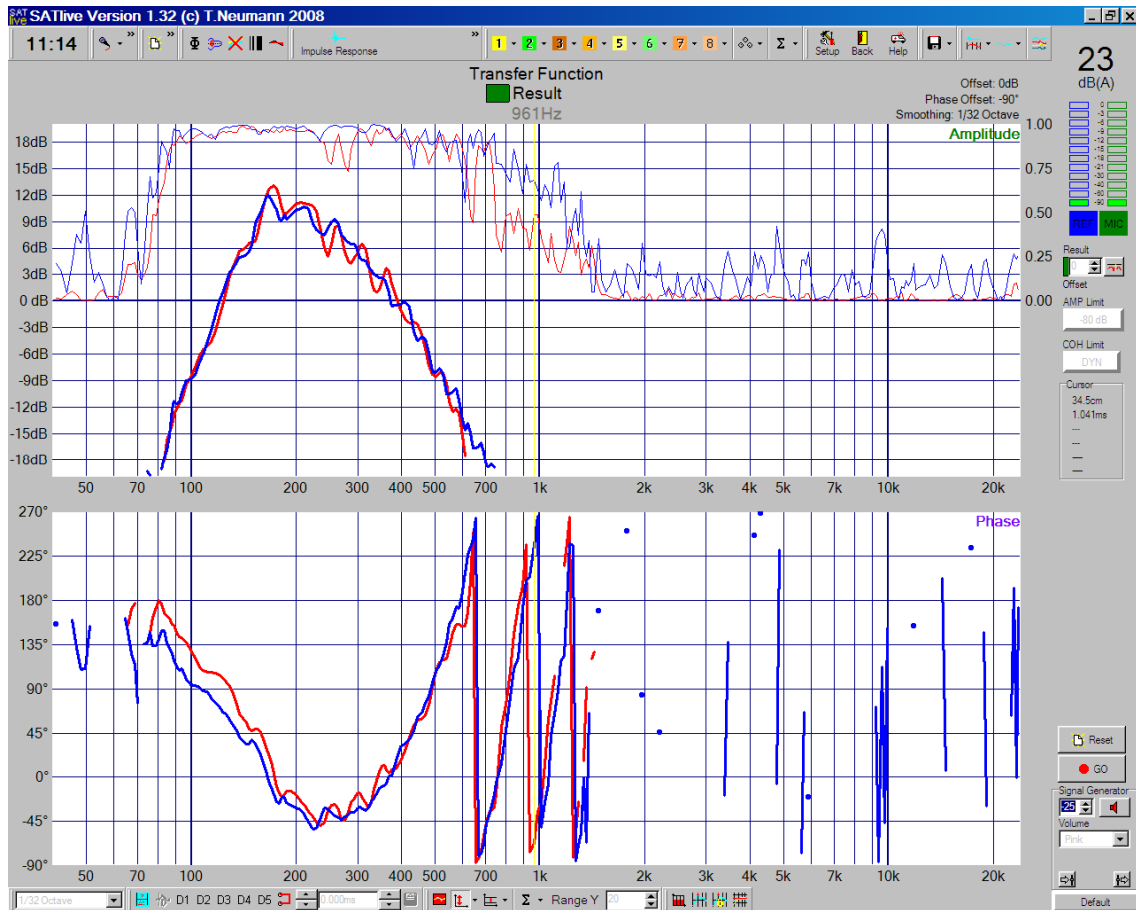

Fig. 18. When adding delay to the blue curve, its phase trace moves down until it overlaps with the red one. Delay added to the backward facing subwoofer in this example was 0.681ms.

9) Invert polarity on the subwoofer facing backward. The phase trace can be seen to shift 180° .

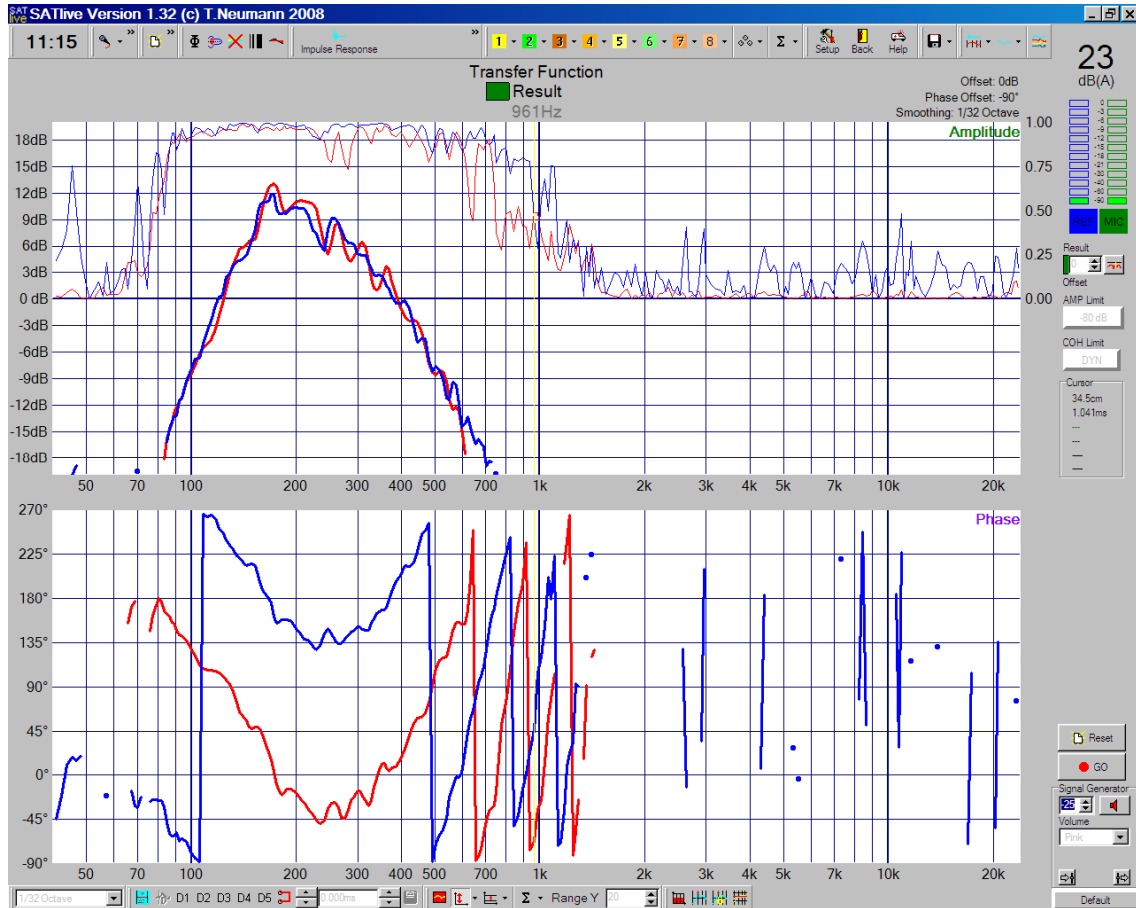

Fig. 19. When the polarity for the backward facing sub gets inverted, its phase curve is the same as that of the forward facing subs, but shifted 180° .

10) Unmute all subwoofers. Measure the amplitude response of the adjusted system and compare to the initial measurement for the forward facing subwoofers. If the phases have been correctly adjusted we shall see a significant reduction in level.

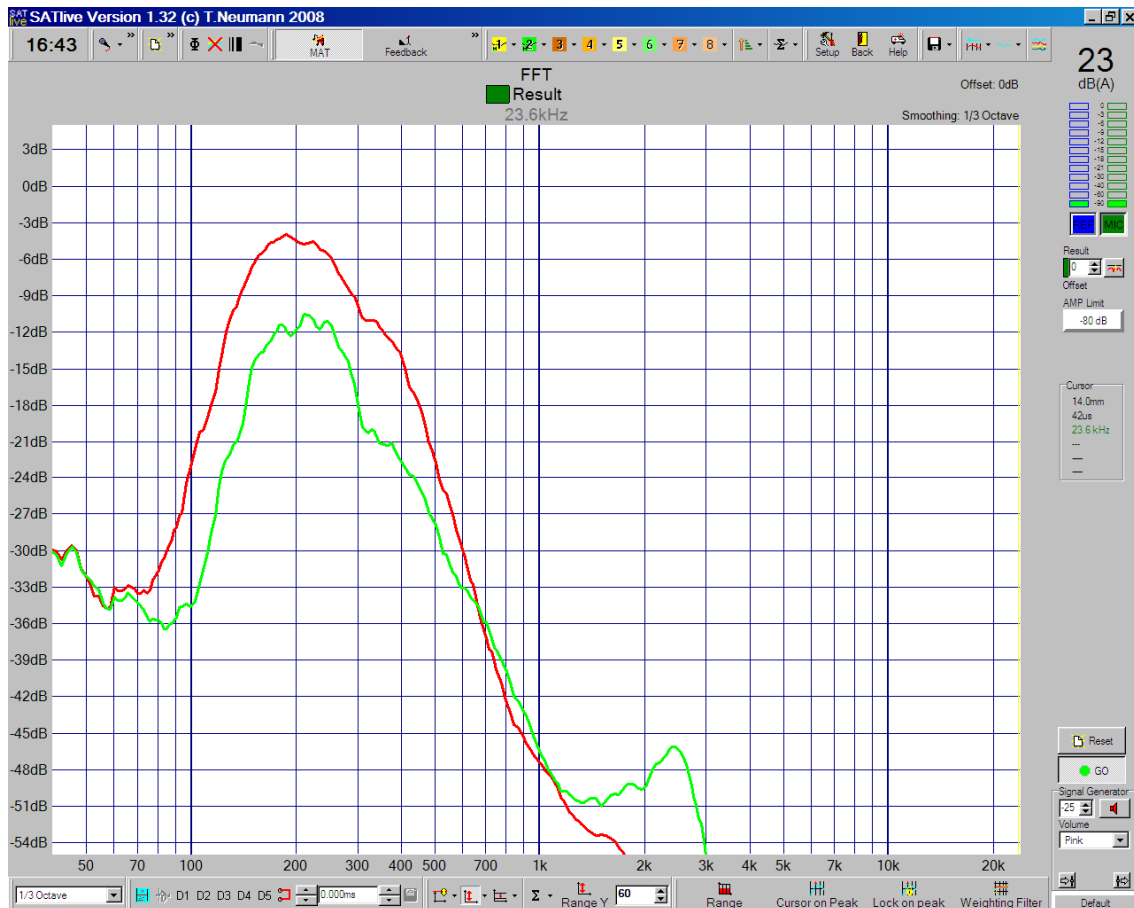

Fig. 20. This image compares the pressure curve of the forward facing subwoofers at the measurement position (red trace) to the cardioid configuration (green). In this case, a difference of up to 9dB can be seen.

We recommend that you now listen to the result by walking from the front to the back, around the system. The difference should be remarkable.

We can also listen to the difference with pink noise by asking someone to mute the output of the backward facing subwoofer.



11) Adjust the processor limiters so that both subwoofers limit at the same time.

In step 7 we increased the gain on the backward facing subwoofer in order to match the levels at the back of the arrangement (Keep in mind that, for optimum cancellation, phase difference needs to be 180° and levels need to be matched).

If we did not adjust the limiters this way, the backward facing subwoofer would limit before the frontward facing ones, so, for a moment, pressure levels would not be the same and there would be an annoying intermittent lack of cancellation.

This adjustment can be done with a music signal, varying the limiter threshold at the processor outputs so that limiting for the two signals takes place at the same time.

Downloaded from Doctor ProAudio.com

Sound pressure level in front of the cardioid configuration

Not all the back subwoofer energy is used for cancellation. At the front of the cardioid configuration pressure is gained, compared to a conventional configuration (without a backward facing subwoofer, that is).

Figure 21 shows the sound pressure difference between the subwoofers facing the audience and the cardioid configuration.

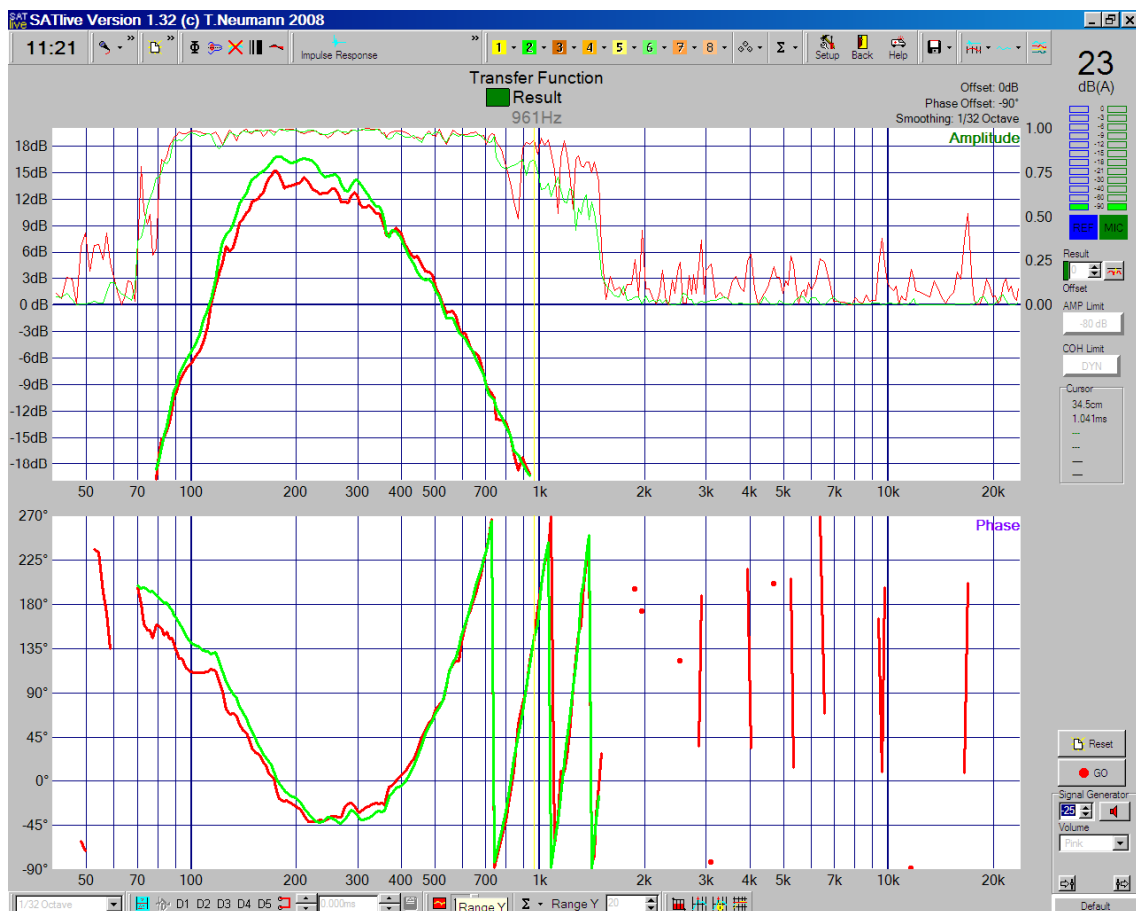

Fig. 21. Red traces correspond to the magnitude and phase responses for the subwoofers facing the audience, while the green ones are for the cardioid configuration.

In this specific example, we have gained approximately 3dB between 135Hz and 250Hz. Above 250Hz the difference gets gradually reduced up to 360Hz, where levels become equal. Below 135Hz the difference decreases gradually until the levels become the same at 115Hz.

¿How does this configuration work?

Basically, it follows the same principles as the previous configuration, but in this case diffraction plays a more important role. Subwoofer enclosure dimensions and the configuration itself have a decisive effect on propagation times for the backward wave and therefore on the delay to be added. It is advisable to perform actual measurements, as described here, instead of relying on calculations, which may differ due to diffraction effects and the speed of sound.

Anechoic chamber measurements

Polar plots and isobar maps illustrate the effectiveness of this cardioid configuration.

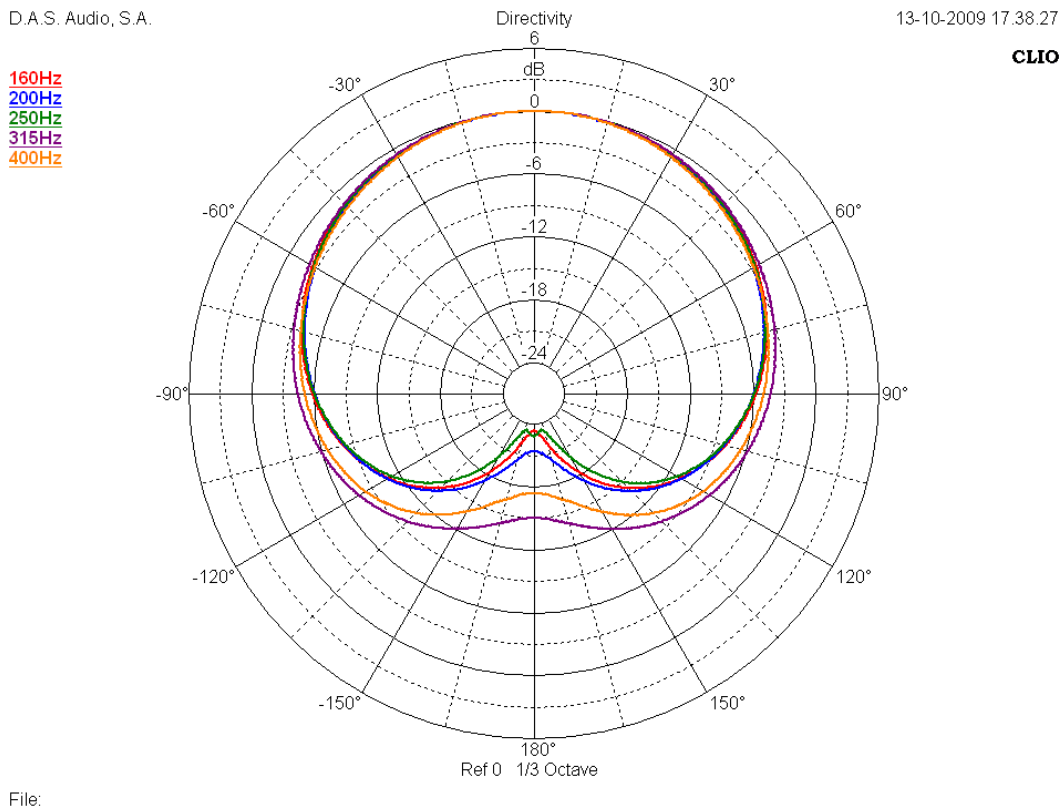

Fig. 22. Polar plots of the cardioid configuration as measured in the anechoic chamber.

It can be clearly seen how a cardioid, heart shaped, pattern is radiated, as desired. The pattern changes slightly with frequency. 160 Hz is the lowest frequency shown, as it corresponds to the anechoic chamber's frequency limit. Keep in mind that you should divide the frequencies shown by 4.5 to calculate the equivalent frequencies for an 18" subwoofer, so that 160 Hz in our scaled down exercise would correspond to 35.5 Hz.

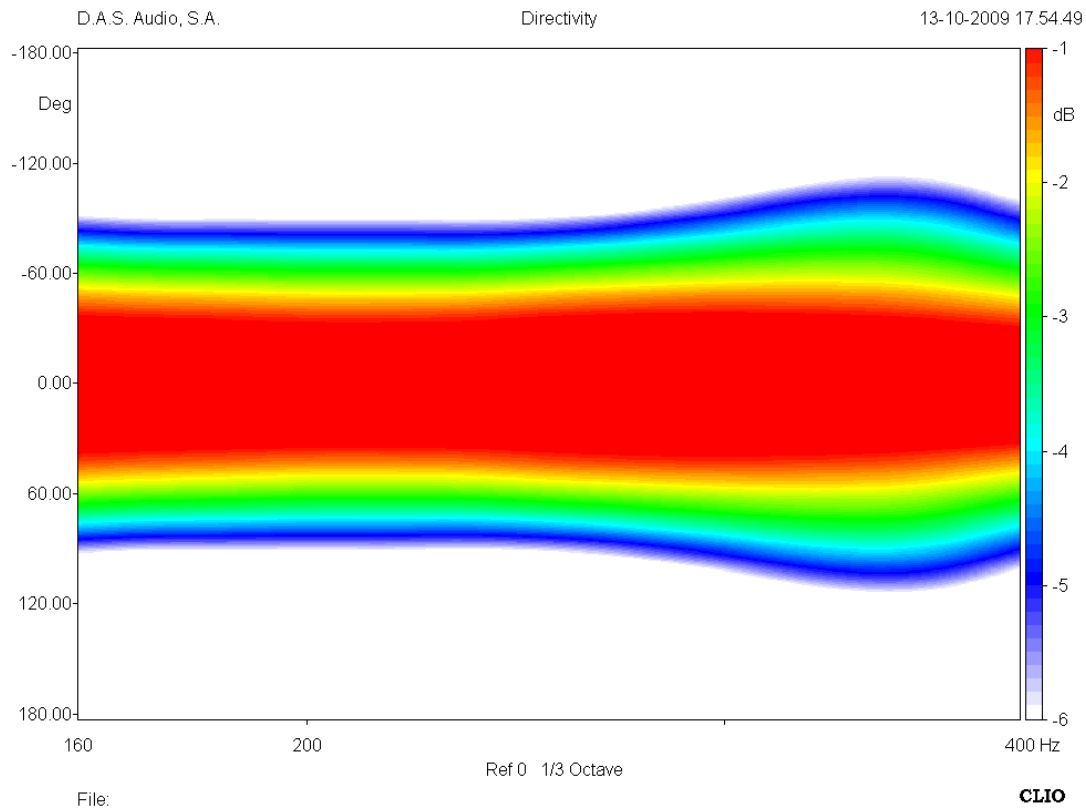

Fig. 23. Isobar map for the cardioid configuration. [Downloaded from DoctorProAudio.com](http://www.DoctorProAudio.com)

Isobar maps represent a system's coverage in degrees (vertical axis) as a function of frequency (horizontal axis). The colour scale on the right-hand side shows that white colour (or the limit with blue) corresponds to -6dB with respect to the centre. It can be seen that we have roughly -6dB at +90° and -90° throughout the band, i.e. a coverage of 180°.

Example 3. “Measurements on a real system: two facing forward and one backward”

In this example our cardioid configuration uses three stacked DAS LX218A subwoofers. The top and bottom ones are facing forward while the centre one is firing backward.

The DAS LX218A subwoofer is a self-powered system incorporating signal processing (crossover and equalization), but we will use an external processor in order to set up the cardioid configuration.

Figure 24 shows the positioning of the subwoofers and the microphone. The top and bottom cabinets, pointing forwards, share the same signal.

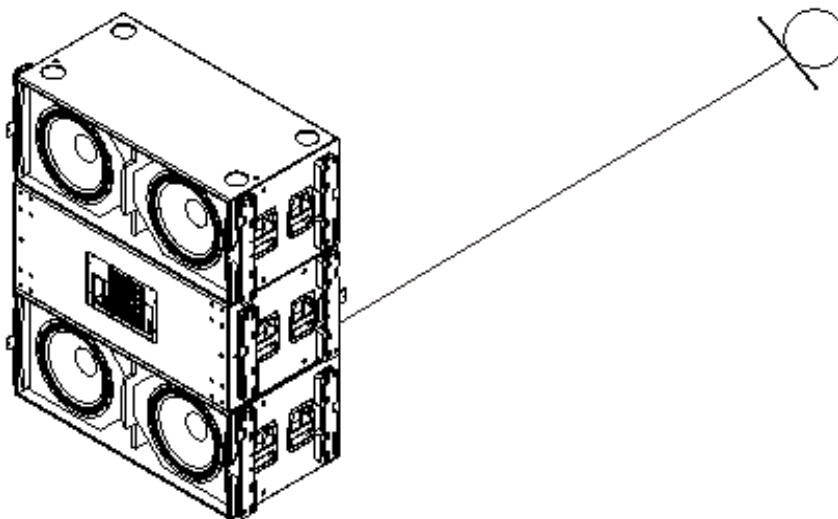

Fig. 24. Positioning of the microphone and cabinets for this example.

The procedure is as follows:

- 1) Place the microphone behind the enclosures, at the spot where we want the cancellation to take place.
- 2) Start with just the band that drives the forward facing subwoofers. We'll use the “Delay Finder” utility to add the required delay on SATLive to the channel carrying the reference signal. (See the user's manual for SATlive or your analysis software for more information).

3) Measure the magnitude frequency response for the enclosures facing forward before doing phase adjustments. This way we'll be able to compare the initial situation with the cardioid configuration. The measurement can be seen in Figure 25. The subwoofers' phase trace will always be shaped like an upper case U letter, or a smile.

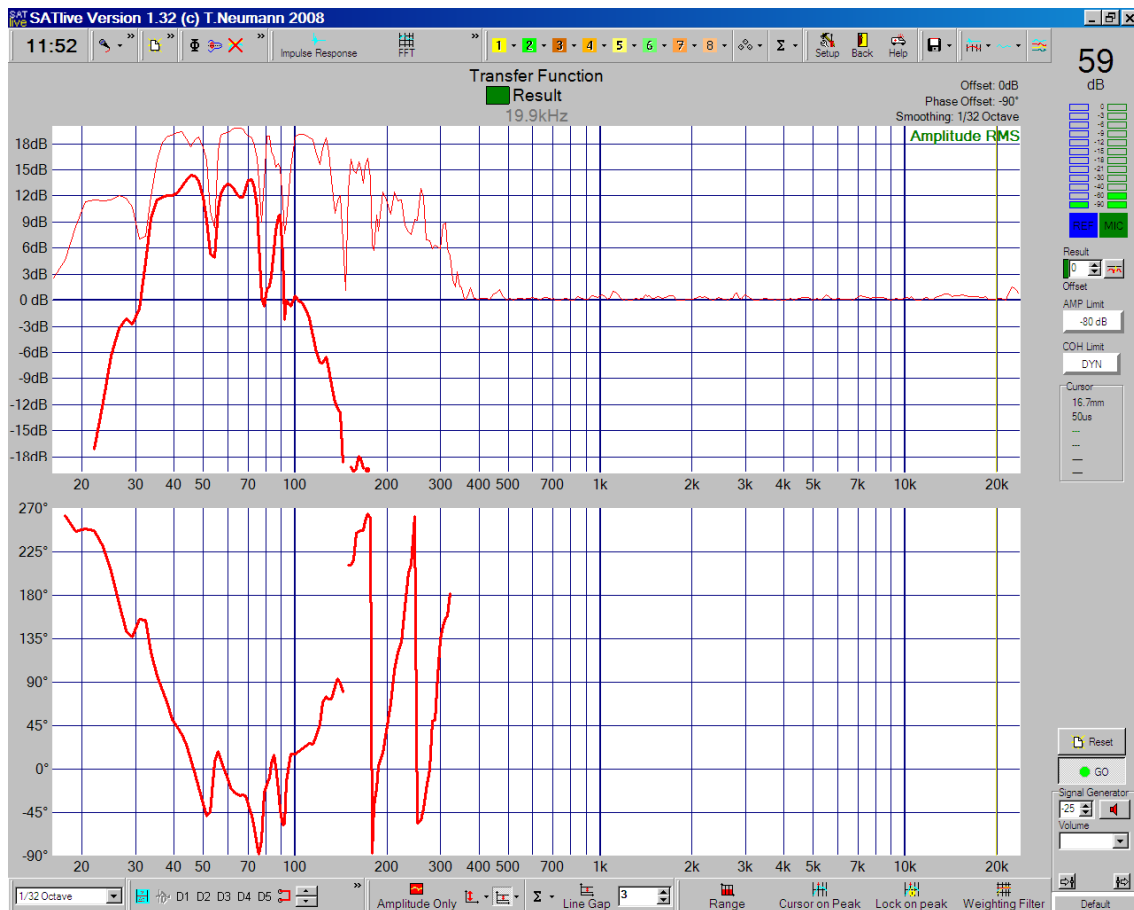

Fig. 25. Magnitude and phase curves for the subwoofers facing forward at the position where the cancellation is required.

This is a real life measurement inside a hall, so the phase response curve shows irregularities due to loss of coherence at certain frequencies. We should be able to recognise the upper case U letter shape, or smile, even if deformed due to coherence loss.

4) Mute the forward facing subwoofers and unmute the backward facing subwoofer.

5) Do not use the “Delay Finder” again!!! (i.e., do not synchronise the reference signal to the measured signal again). Remember that we are comparing phase on the subwoofers, i.e. we are measuring the difference in time arrival between the two signals as a function of frequency. Therefore the synchronisation delay for the reference signal should not be changed on the measurement software again.

6) Measure the backward facing subwoofer and compare the phase and amplitude curves with those of the forward facing subwoofers. The result can be seen in Figure 26.

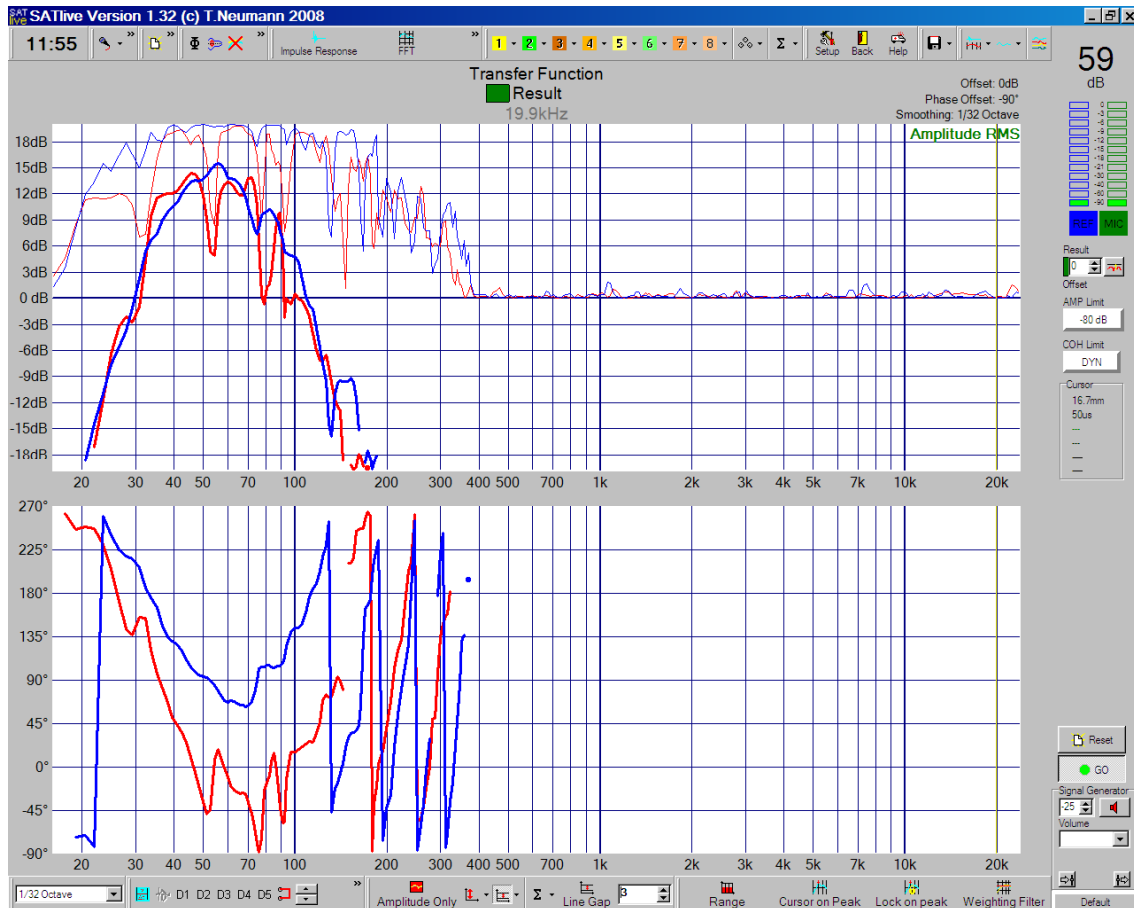

Fig. 26. Comparison of forward facing (red trace) and backward facing (blue) subwoofers. There aren't significant differences in level, but phase differences are evident, as expected.

7) If necessary, adjust the gain of the backward facing subwoofer so as to match the level of the forward facing subwoofers at the measurement microphone. If needed, you could always apply filtering (HPF, LPF or EQ) to match the levels in the whole of the subwoofer passband.

In this case neither gain nor filtering are needed. Both magnitude curves are level matched as seen on figure 26.

8) Add delay to the subwoofer facing backward until its phase trace overlaps with that of the subwoofers facing forwards. Do not forget to save the curves.

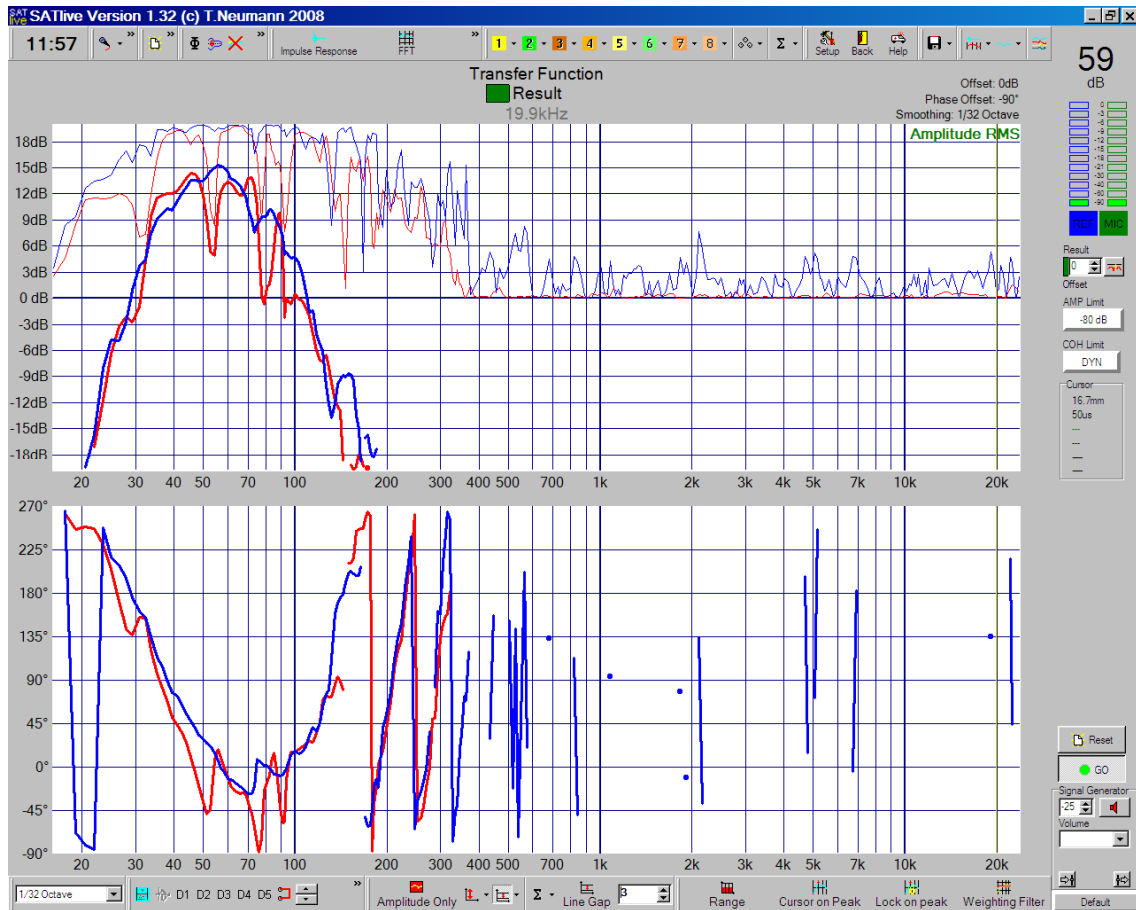

Fig. 27. When adding delay to the blue curve, its phase trace moves down until it overlaps with the red one. Delay added to the backward facing subwoofer in this example was 3.562ms.

9) Invert polarity on the subwoofer facing backward. The phase trace can be seen to shift 180° .

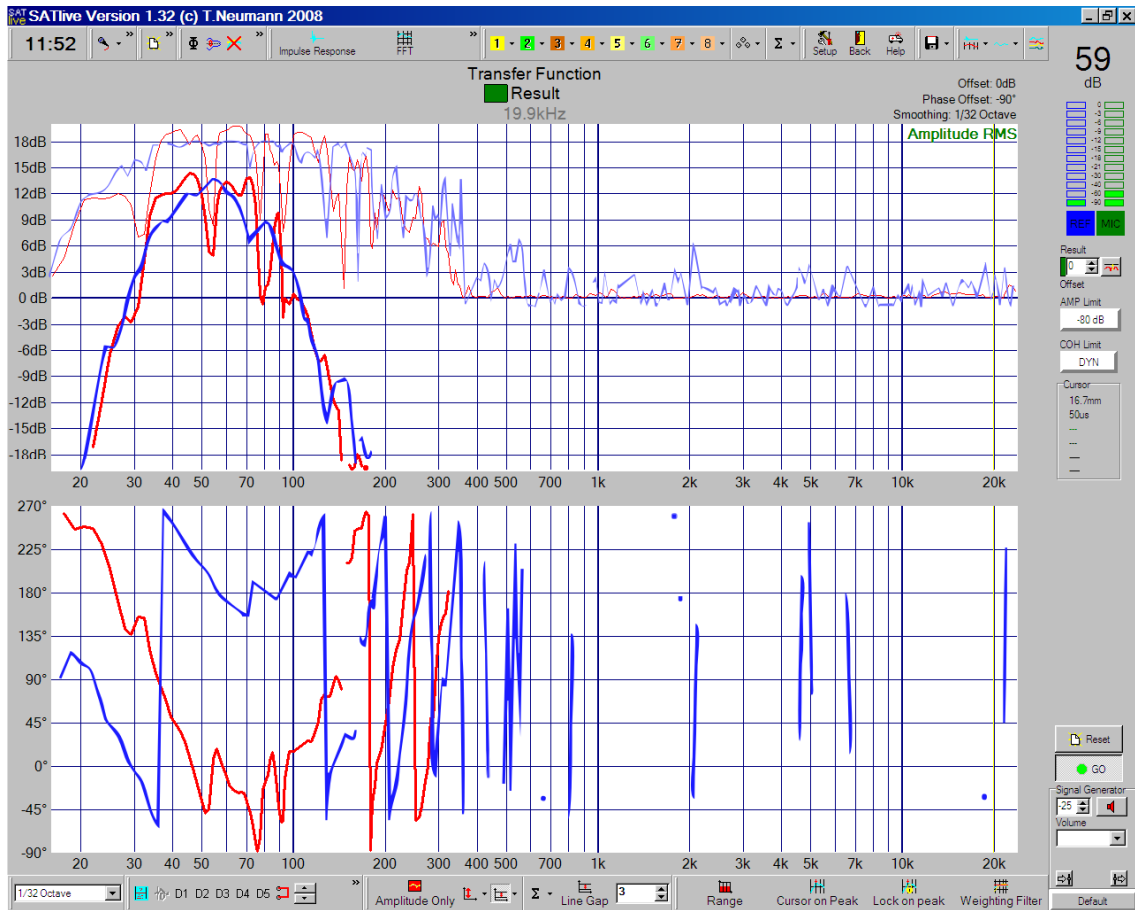

Fig. 28. When the polarity for the backward facing sub gets inverted, its phase curve is the same as that of the forward facing subs, but shifted 180° .

10) Unmute all subwoofers. Measure the amplitude response of the adjusted system and compare to the initial measurement for the forward facing subwoofers. If the phases have been correctly adjusted we shall see a significant reduction in level.



Fig. 29. This image compares the pressure curve of the forward facing subwoofers at the measurement microphone (red trace) to the cardioid configuration (green). In this case, there is a band where a difference of up to 6dB can be seen and another band with differences up to 9 dB .

We recommend that you now listen to the result by walking from the front to the back, around the system. The difference should be remarkable.

We can also listen to the difference between the cardioid configuration and the conventional one with pink noise by asking someone to mute the output of the backward facing subwoofer.

11) If the gain for the backward facing cabinet has been changed, adjustments to the processor limiters will be required so that both subwoofers limit at the same time.

In this example, the gain did not need to be modified, so no adjustment on the limiters is necessary.

Sound pressure level in front of the cardioid configuration

Not all the back subwoofer energy is used for cancellation. At the front of the cardioid configuration, pressure is gained, compared to a conventional configuration (without a backward facing subwoofer, that is).

Figure 30 shows the sound pressure difference between the subwoofers facing the audience and the cardioid configuration.

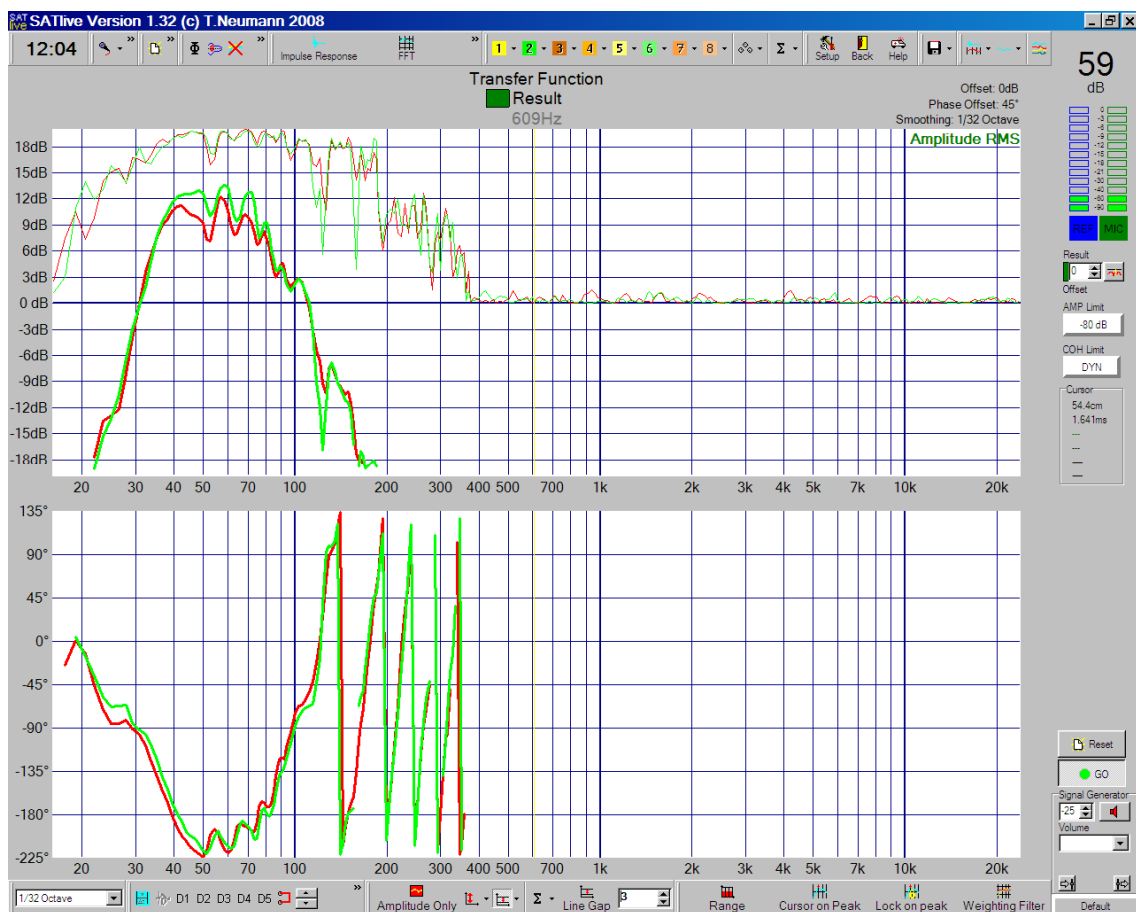

Fig. 30. Red traces correspond to the magnitude and phase responses for the subwoofers facing the audience, while the green ones are for the cardioid configuration.



In this specific example, we have gained approximately 3dB between 40Hz and 75Hz. Above 75Hz there is practically no difference and below 35Hz levels are also the same.

Before adjusting a real system for the first time, it makes sense to practice this procedure as often as possible and with whatever combination of gear we happen to lay our hands on, until we have mastered the technique. Using scaled down systems will allow us to become familiar with the procedures until we are confident to try larger systems.

And, above all, don't be scared of trying things out (first with scaled down systems and at home, your warehouse, workshop, etc). If there is something that you have not quite grasped, practice will clarify it.

**Joan La Roda.
DAS Audio, Engineering Department.**

Copyright © DAS Audio 2009

Downloaded from Doctor ProAudio.com